

Introduction

MAF700 series by Inelmatic Electronics is the new generation rugged milling metal frame monitor with waterproof function, which follow IP65 ingress protection (IP67 optional), low power consumption, super fast reponse time. It's the ideal solution for outdoor usage, or harsh environments.

The MAF700 includes a high featured controller with automatic and manual backlight adjustment, depending of the ambient light, which makes it suitable for applications from the darkest night(NVIS) to the bright sun light. Besides, the MAF700 optionally includes a resistive / capacitive (PCAP) touch panel with USB controller, adding interactivity.

The MAF700 is available with VGA input as standard, optional DVI / HDMI, Composite Video and S-Video inputs. All inputs are available as factor option on the rear panel. Optionally it includes "all-in-one cable", with a lockable connector for an easy and quick installation.



Main features

- * High brightness ultra-low power LED backlight.
- * **Resistive / Projected Capacitive (PCAP) touch optional.**
- * Sunlight readable.
- * **7-36V DC power supply.**
- * Low power consumption.
- * **Two composite video, one with autopower / autoswitch.**
- * Autopower on/off by VGA signal.
- * **All-in-one cable, 2.5m and 4.5m length options.**
- * Automatic backlight dimmer.
- * **Wide temperature range.**
- * Milling aluminium front and metal folding behind.
- * **Customization available for small qty.**

Drawing

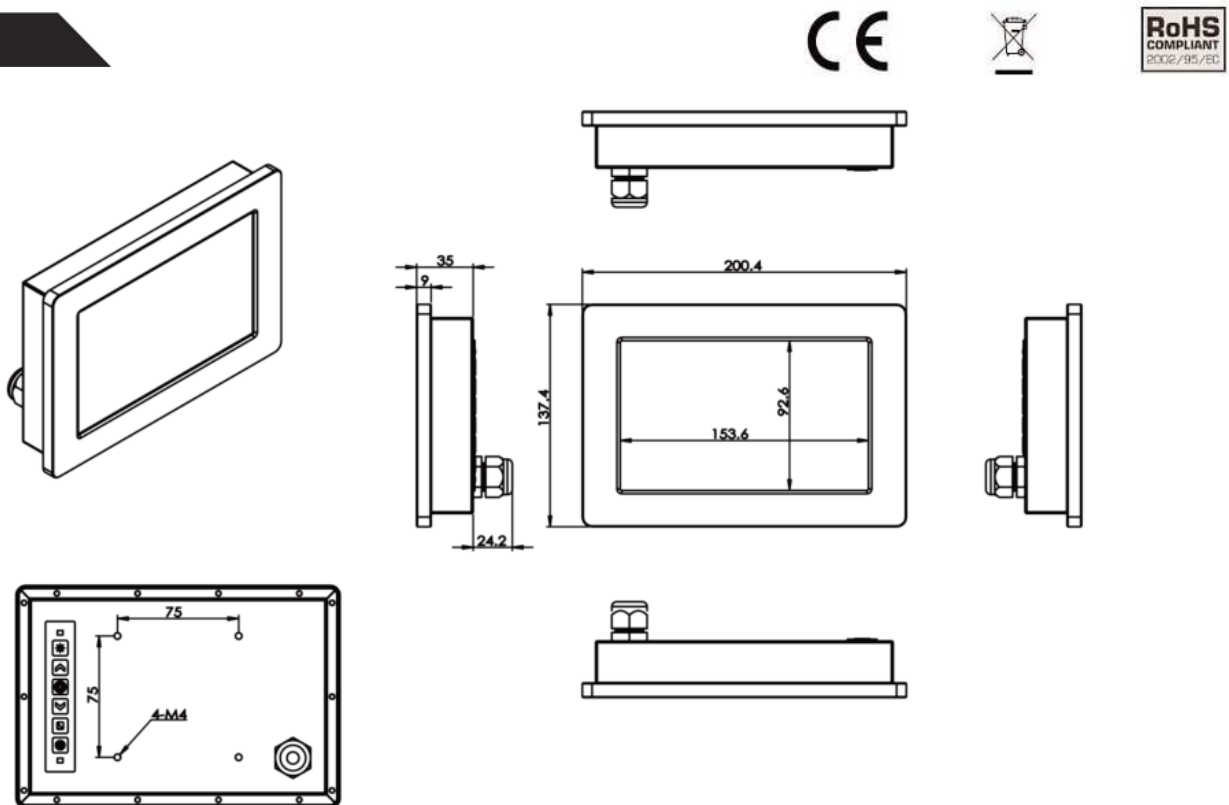

Specifications

Size	7 Inches XGA TFT Liquid Crystal Display
Aspect	16:9
Inputs	VGA, HDMI, DVI, 2x AV optional
Audio	None
Touch Panel	Resistive/Capacitive touch(PCAP), 3mm Chemically Strengthened Cover Lens
Power supply	7-36VDC
Power consumption	6W
Mounting	VESA 75mm, customization available
Warranty	12 months international, 24 months Europe.
Certification	CE*, RoHs, IEC60945*, EN50155* and EN45545*,*under customer request.

Mechanical and enviromental specs

Dimensions	200.4 x 137.4 x 35 mm
Weight	1050gr
Enclosure	Milled Aliminum , folded Aluminum
Operation temperature	-30°C to 75°C
Storage temperature	-40°C to 85°C
Vibrations / Shock	1G rms / 40G 11ms
Environment	IP65 chassis
Material	Milling aluminium parts, black anodized/ powder coating
Others	Low flamability, Halogen Free

Optical specifications

Brightness	600nits
Contrast	500:1
Colors	256K
Native resolution	800x480px
Outdoor readability	Meets MIL-STD-3009 (sunlight readable version MAF700HB-US / UPS)
NVIS	Optional NVIS B compliant

ORDER INFORMATION

	MAF700XX-X Y V A - XX	
XX - HB : High Brightness T : Normal Brightness	XX - Surface treatment R : Glossy RG : Diffuse
X - Touch Screen Option U : USB N : W/O Touch panel	A - Audio Option N : W/O Audio A : Stereo Audio
Y - Optical Option N : Normal D : Day Light readable S : Sun Light readable	V - Video Option N : W/O Video V : Video input

Example: MAF700HB-UPSVN4.5 7 inches 800x480px Panel, 600nits, sunlight readable, PCAP touch, video, 4.5m all-in-one cable